

NuKlip

38mm Casement Window

Technical Catalogue

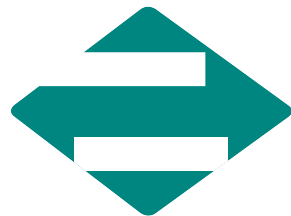

almin

almin metal industries limited

ALMIN PARK
Corner Willowvale & Dagenham Roads
Willowvale, Harare
P O Box ST394
Southerton
Harare
Zimbabwe

Telephones : +263-4-620111/2/6/7/9
Email : tmungure@almin.co.zw
: tmanjeya@almin.co.zw
: customerservice@almin.co.zw
Website : www.almin.co.zw

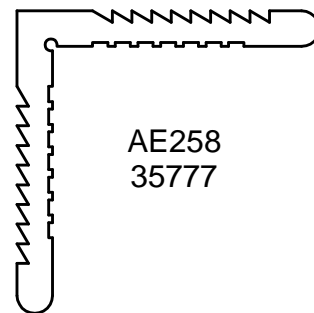
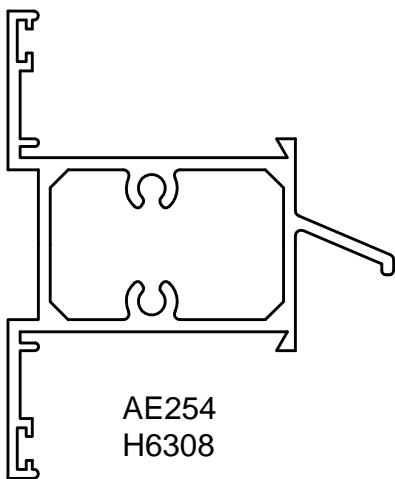
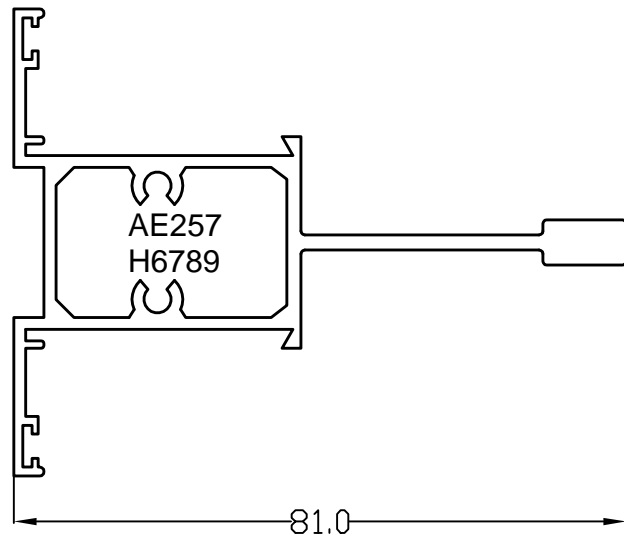
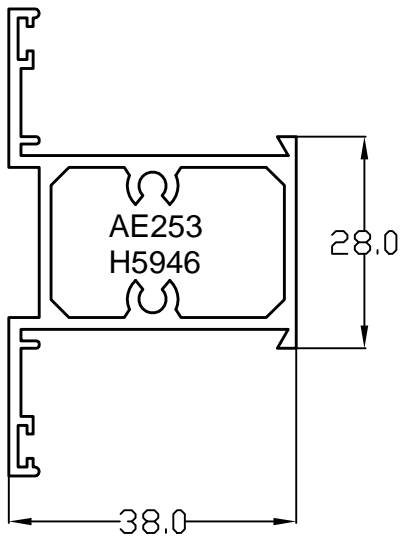
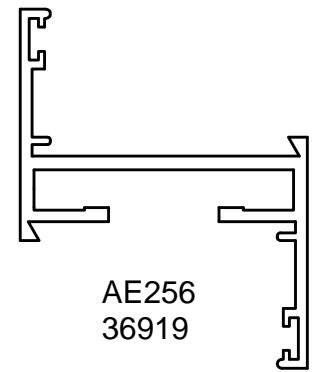
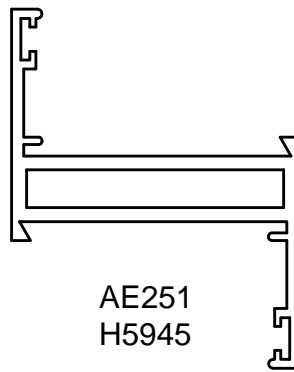
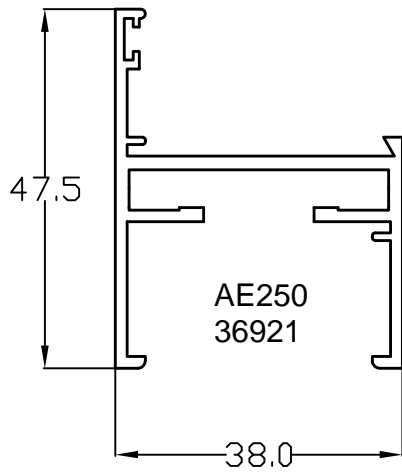



AE258 TC
37909

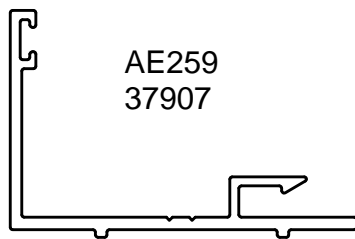

AE259
37907

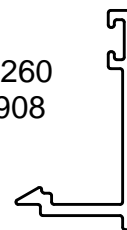

AE260
37908

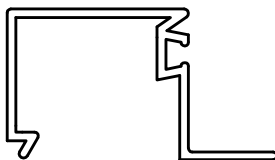

AE255
(NOT IN PRODUCTION)

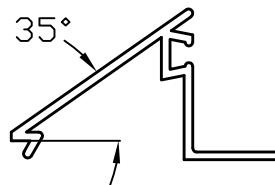

AE252
36920

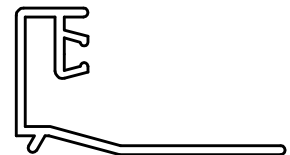

AE38/24
43554



**NuKlip 38 Casement Window Systems
SIZE LIMITATION CHART at 740Pa**

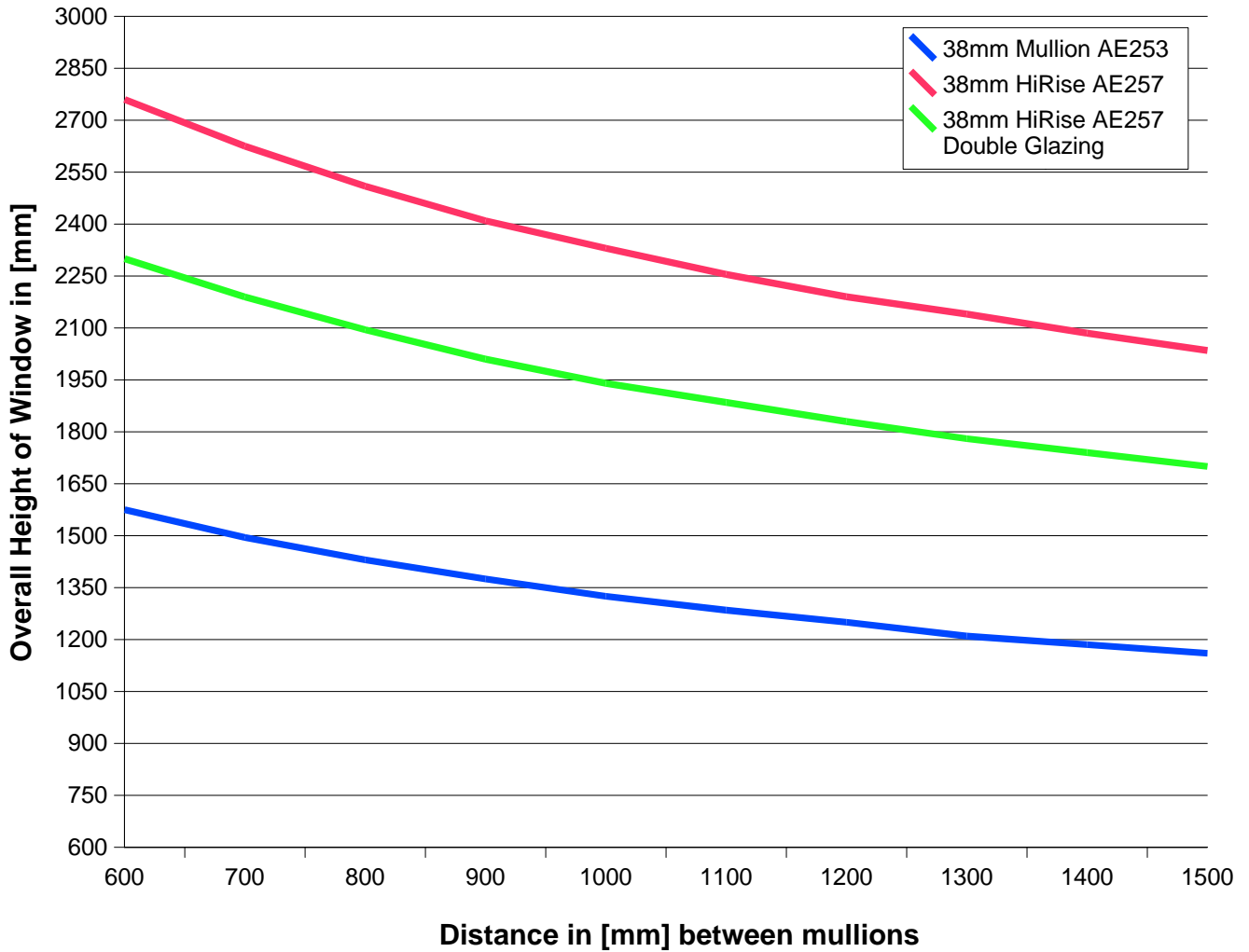

* Almin Metal Industries Ltd do not accept any liability for the use of this chart.
If in doubt, we provide provide the Engineering Advise free of charge to assist with these issues.

Deflection Limit : Height/175 or 20mm, whichever is less. Double glazing: Height/300 or 8mm, whichever is less.

NuKlip 38mm Transom Carrying Capacity (Applies to Fixed Glazing Only)

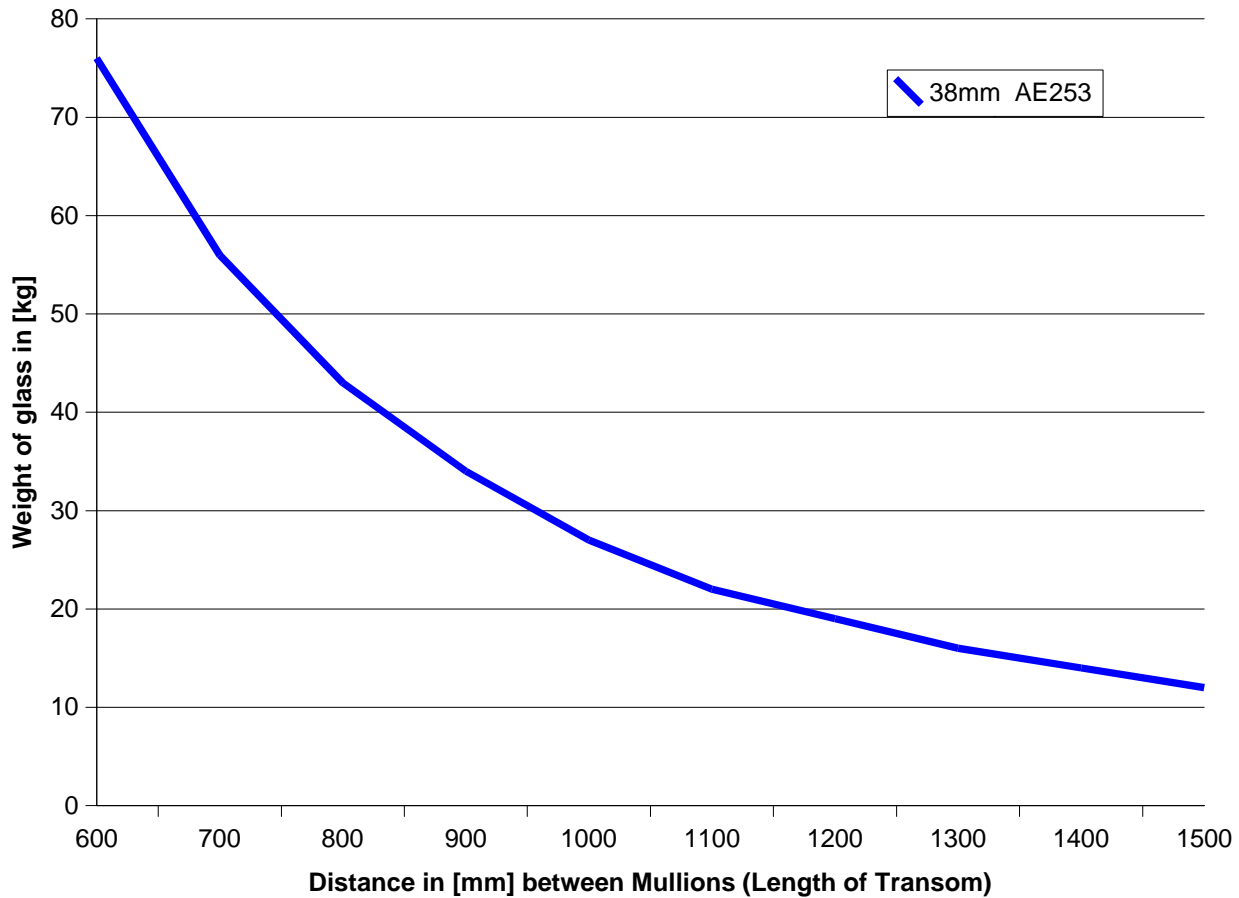

Deflection Limit : $L/1000$ or 2mm, whichever is less. Glass is assumed set on Packers at $\frac{1}{4}$ span of transom.

NOTE!

The values indicated above are theoretical values for the Transom profile only.

It is the responsibility of the fabricator to ensure that the Transom-to-Mullion connections can carry the weight.

* Almin Metal Industries Ltd do not accept any liability for the use of this chart.

If in doubt, we provide provide the Engineering Advise free of charge to assist with these issues.



Note:
For sash width > 700mm use TWO handles

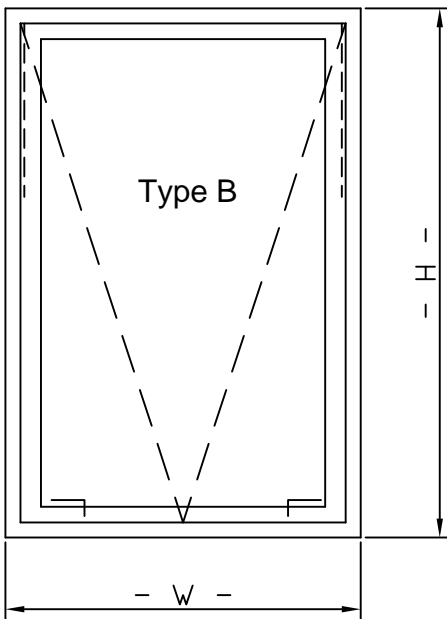
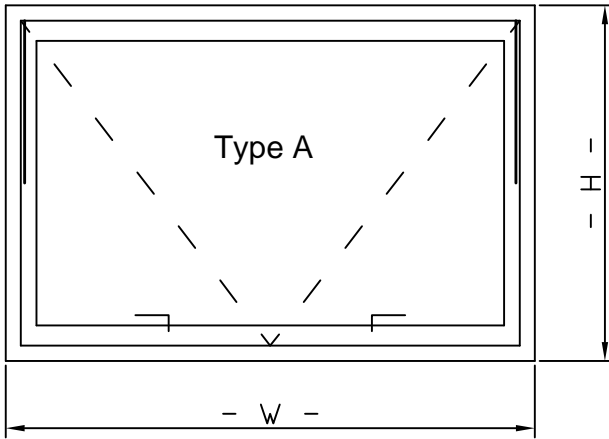

	W mm	H mm	Max Glass Thickness
A			
Top Hung			
38mm Sash	1200	600	4.0mm
B			
Top Hung			
38mm Sash	900	1200	4.0mm
C			
Side Hung			
38mm Sash	600	1500	4.0mm

The above recommended maximum sizes are a combination of the following considerations:

- 1) Windloading of 1000Pa.
- 2) Maximum deflection the lower of L/175 or 20mm.
- 3) Capabilities of interlock Friction Stays held in stock.
- 4) The industry practical multiples of 300mm for window sizes.

RECOMMENDED MAXIMUM SIZES FOR PROJECT-OUT SASHES
INCOPORATING INTERLOCK FRICTION STAYS

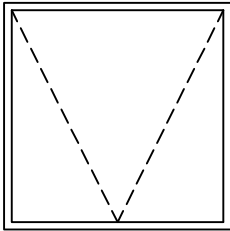

Top Hung

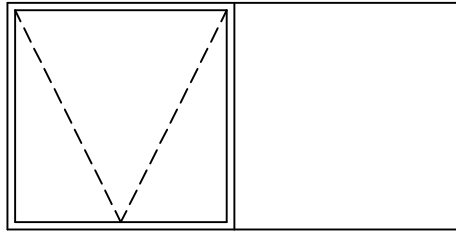

Top Hung / Fixed

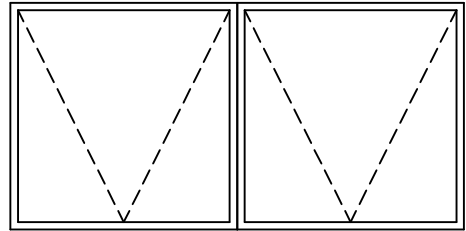

Top Hung / Top Hung

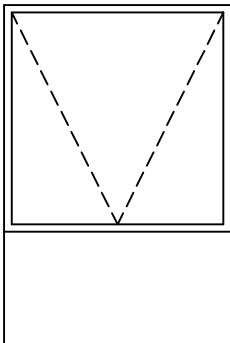

Top Hung Fixed

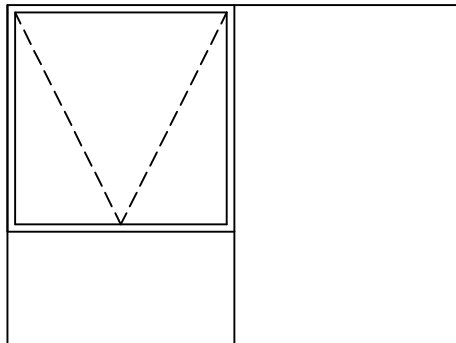

Top Hung / Fixed Fixed

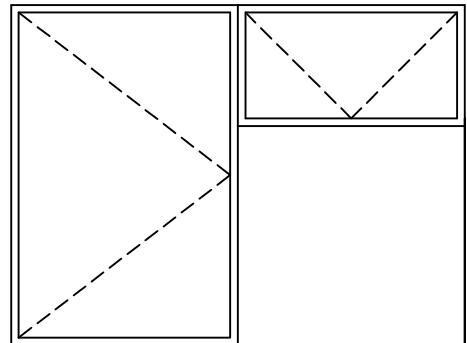

Side Hung / Top Hung Fixed

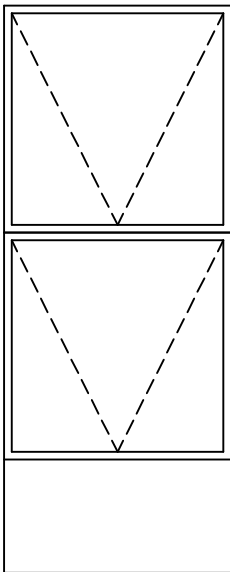

Top Hung
Top Hung
Fixed

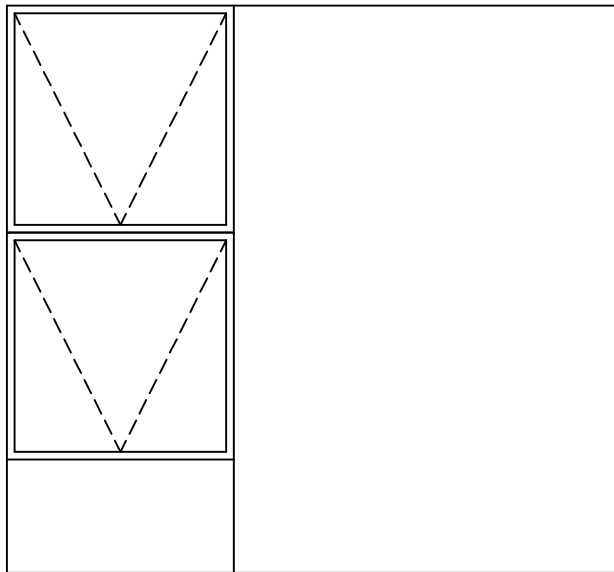

Top Hung / Fixed
Top Hung
Fixed

Often used Project Out Window Types
Schematic Elevations

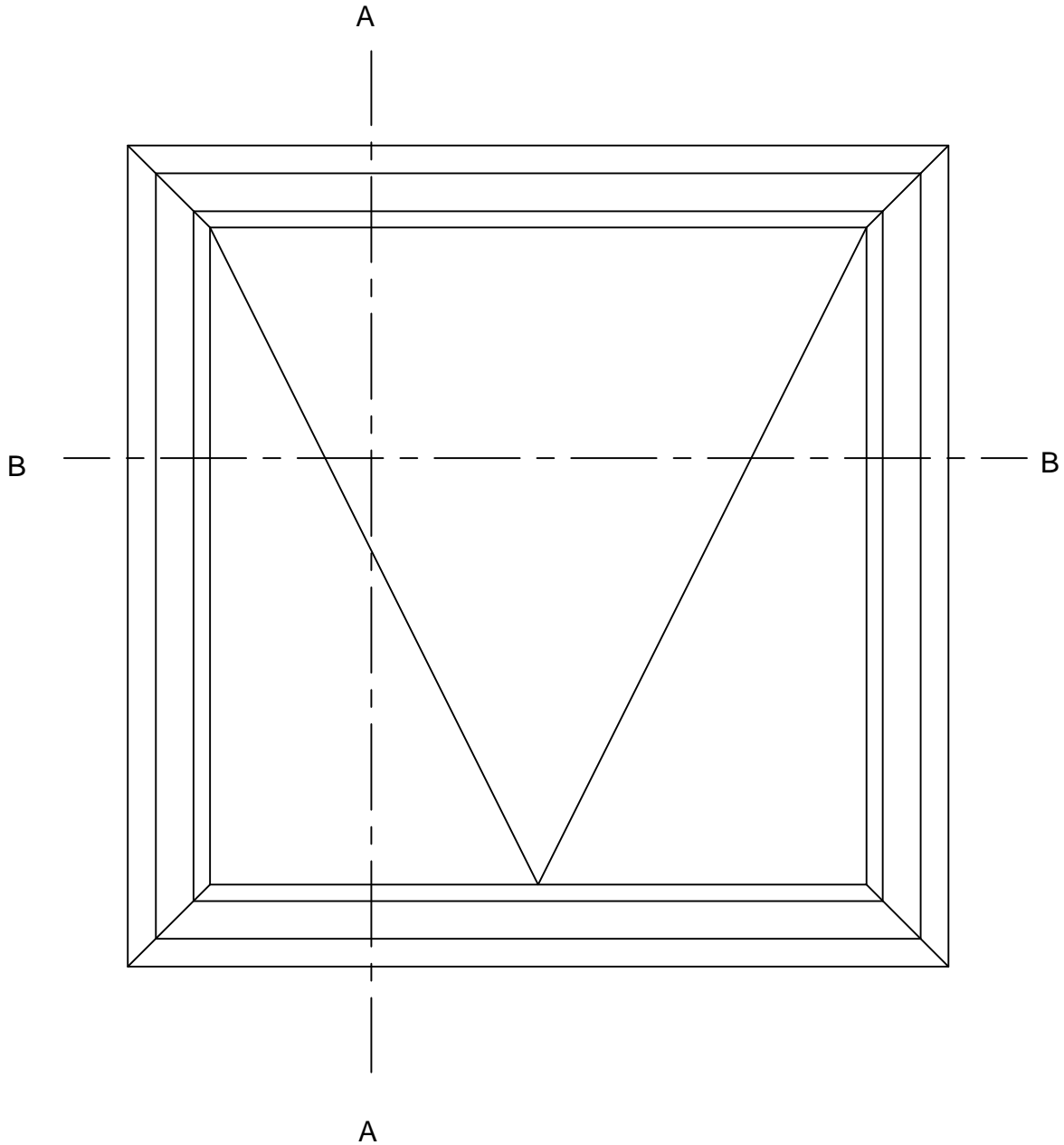

Typical Elevation of Top Hung Window



Section A - A

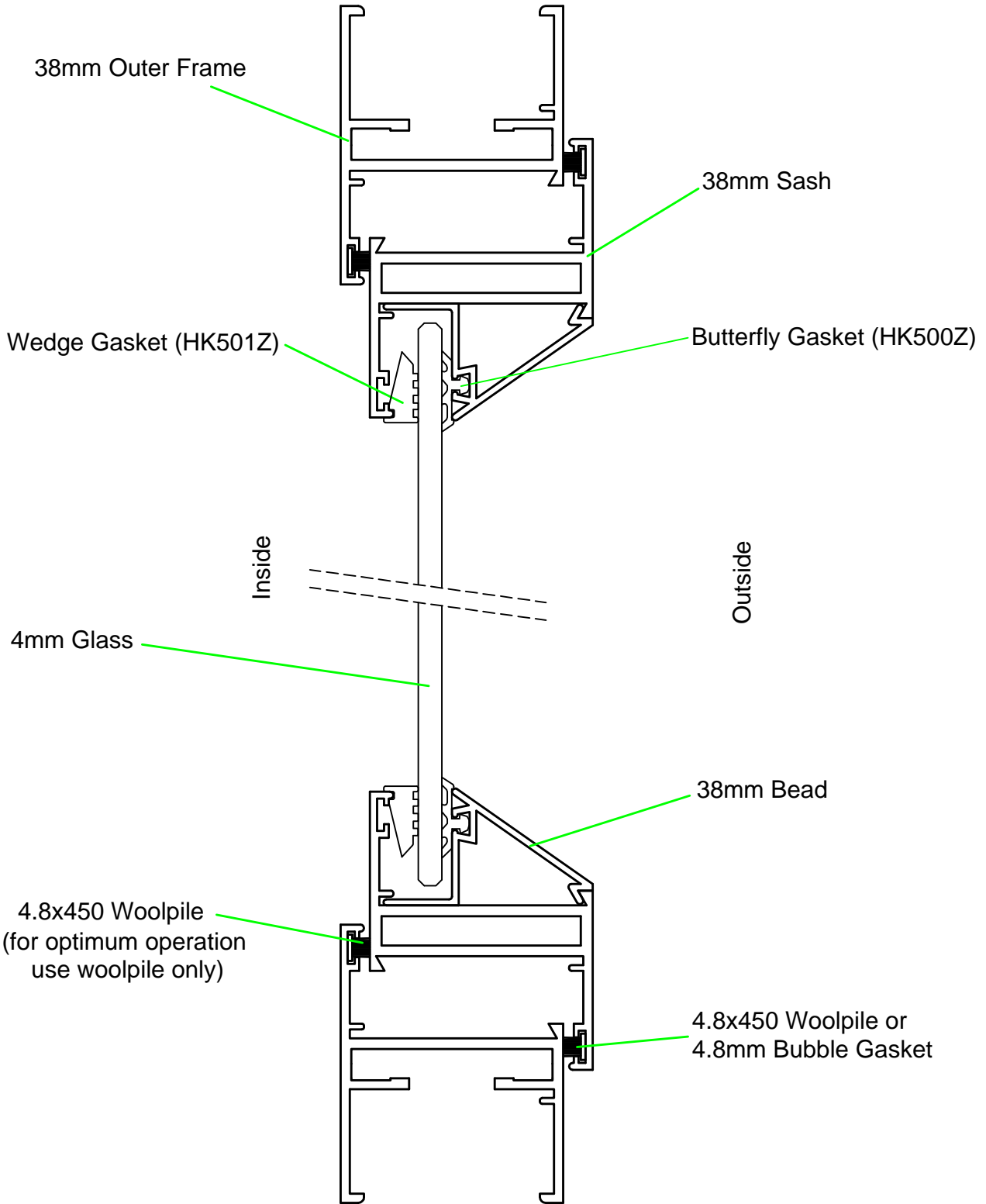

Overall Horizontal Cross Section through Sash and Outer Frame



Section B - B

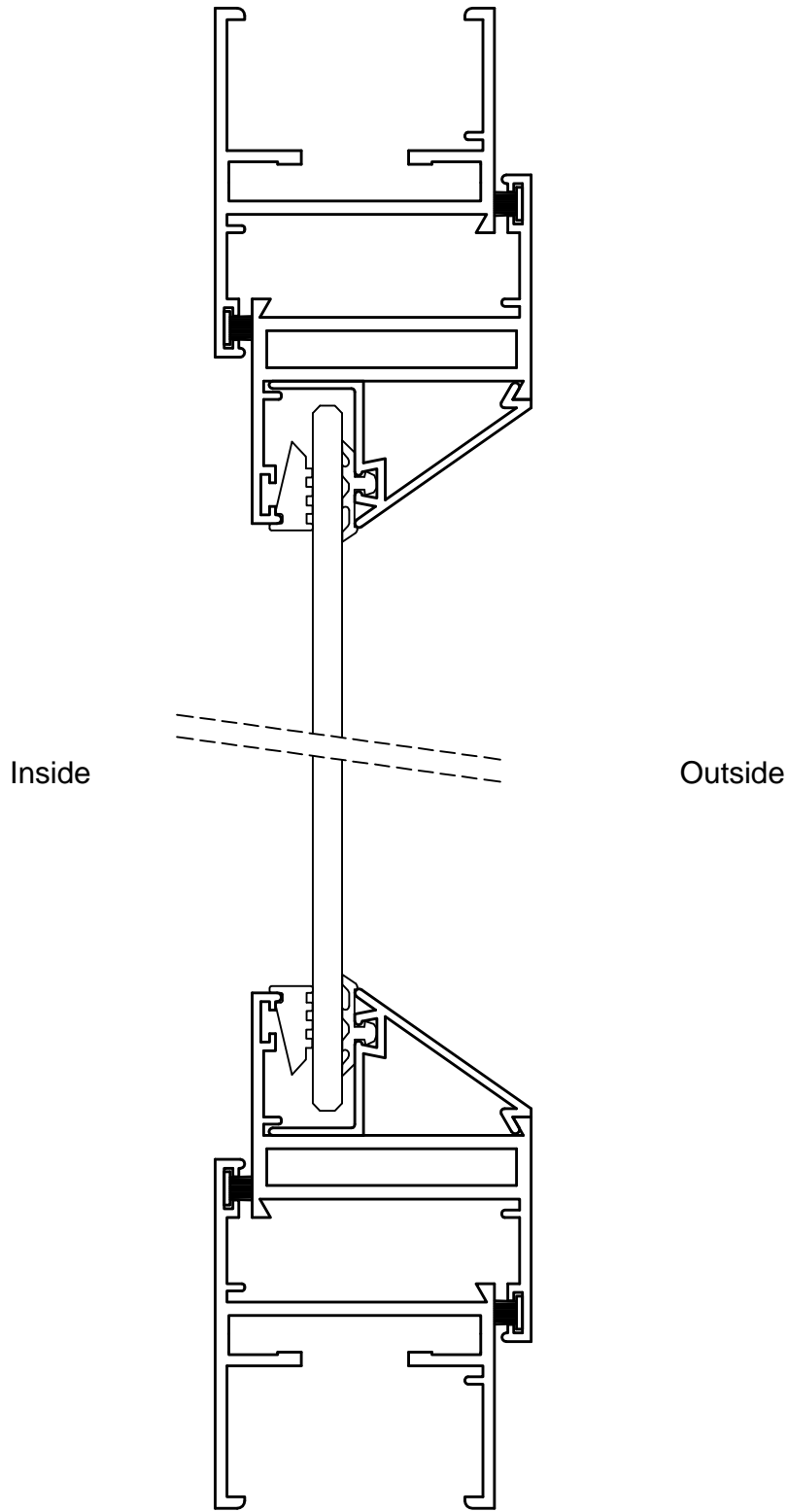

Overall Vertical Cross Section through Opening Sash and Outer Frame



SECTION B - B

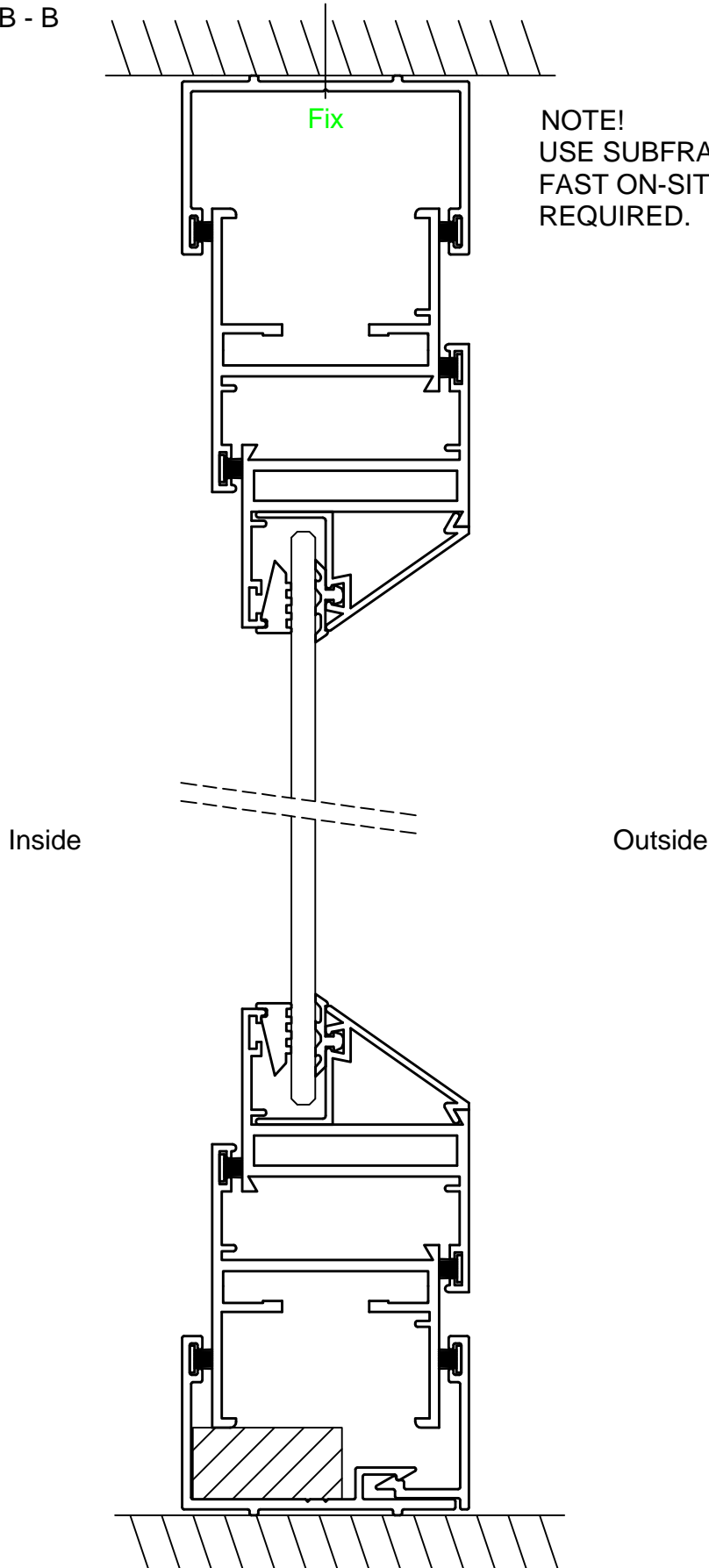

NOTE!
USE SUBFRAME SECTIONS WHERE
FAST ON-SITE INSTALLATION IS
REQUIRED.

Inside

Outside

Vertical Section through Opening Sash and Outer Frame
Recommended fixing method using a Subframe

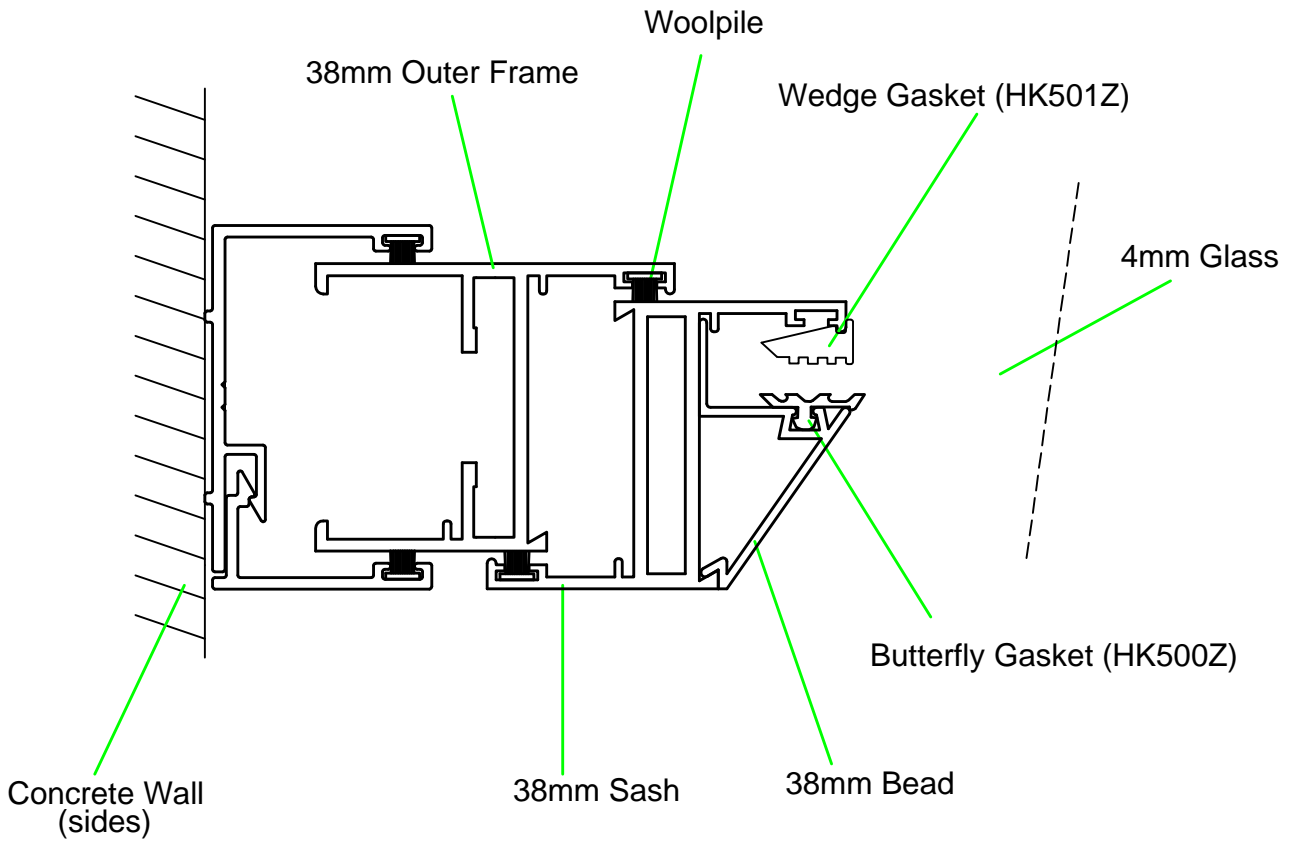

Outer Frame/Opening Sash Detail
Recommended fixing method using a Subframe

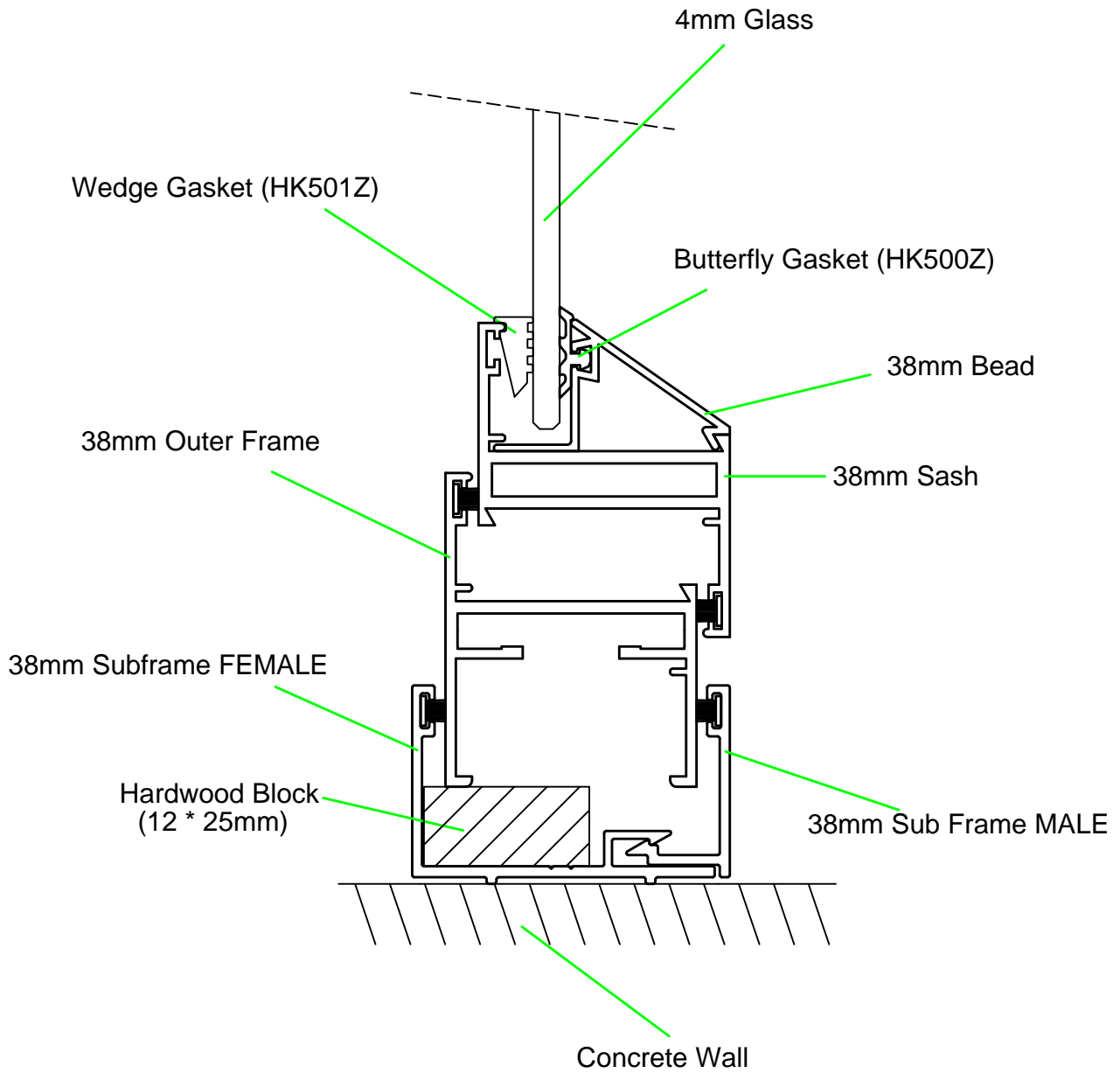

Opening Sash and Outer Frame details
Recommended fixing method using a Subframe

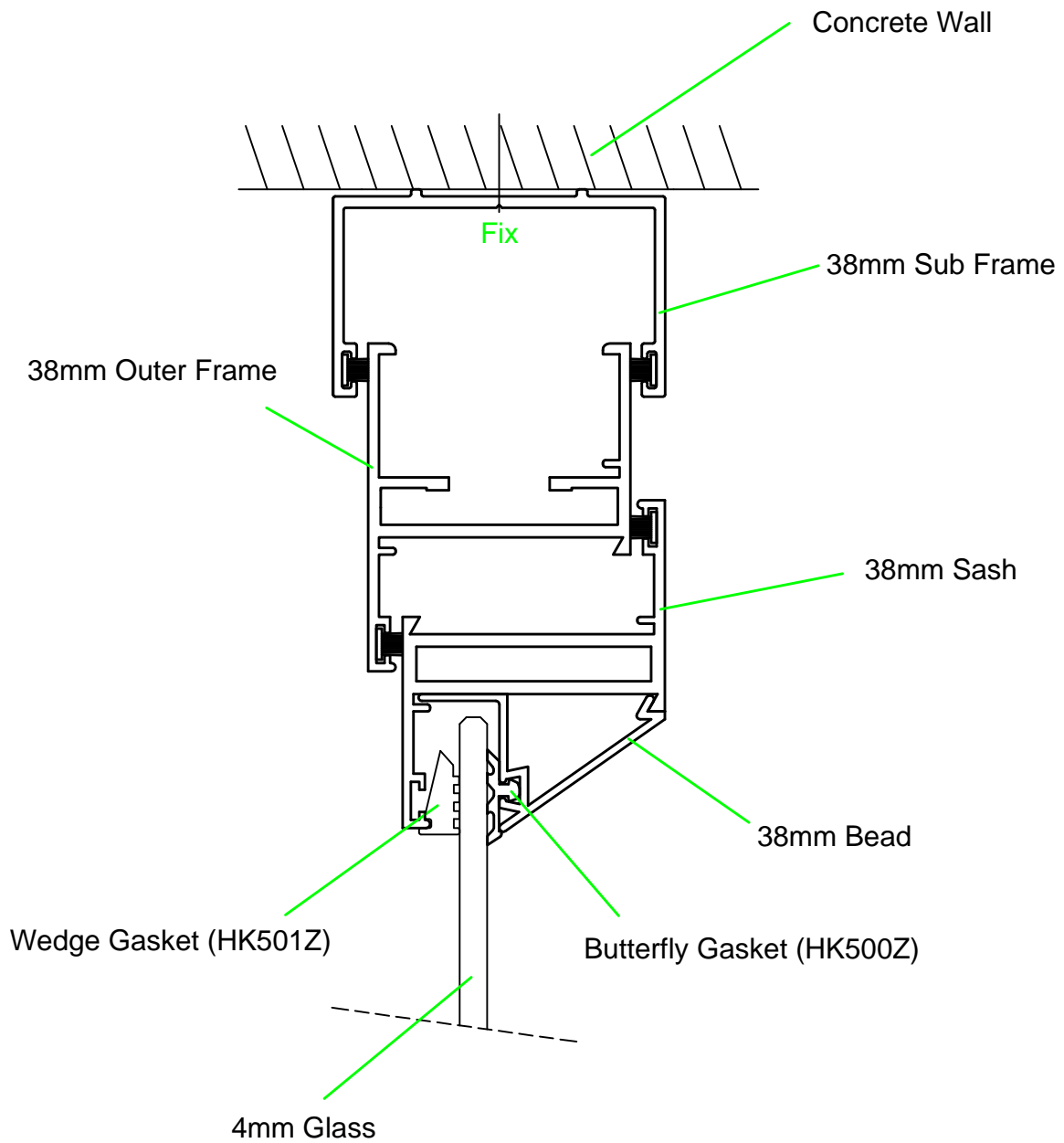

Opening Sash and Outer Frame details
Recommended fixing method using a Subframe



SECTION B - B

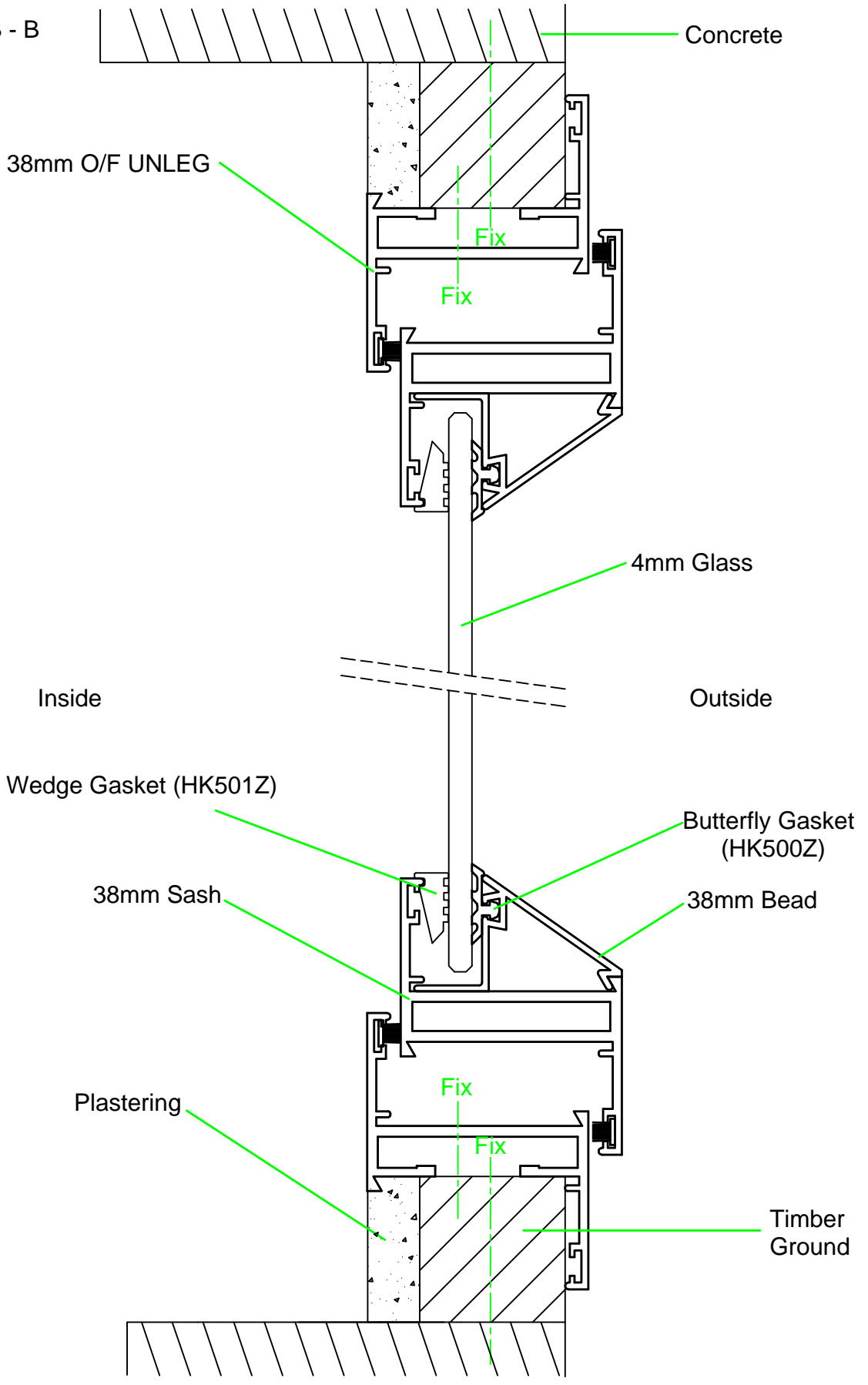

Section through Frame and Opening Sash
utilising Unequal Leg Outer Frame

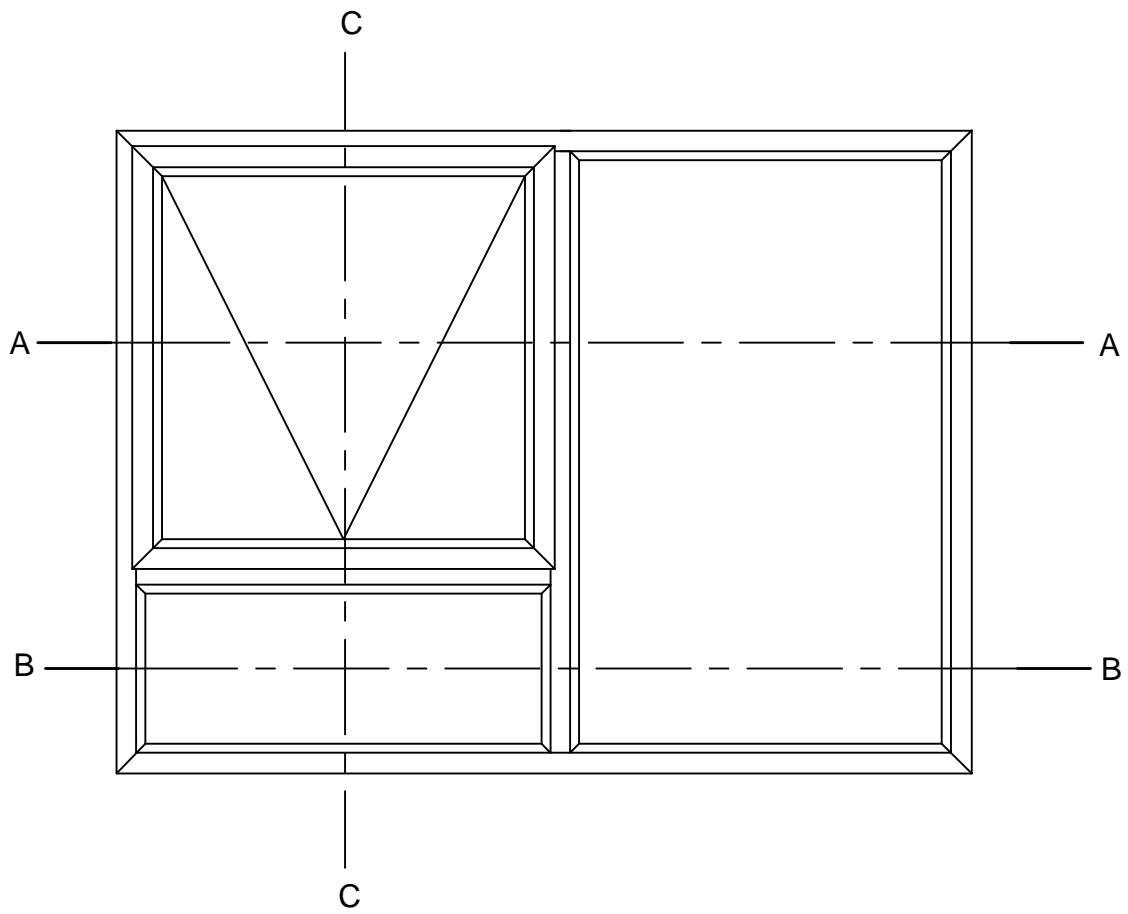

Typical Window Elevation with Top Hung Sash and two Fixed Panels



SECTION A - A

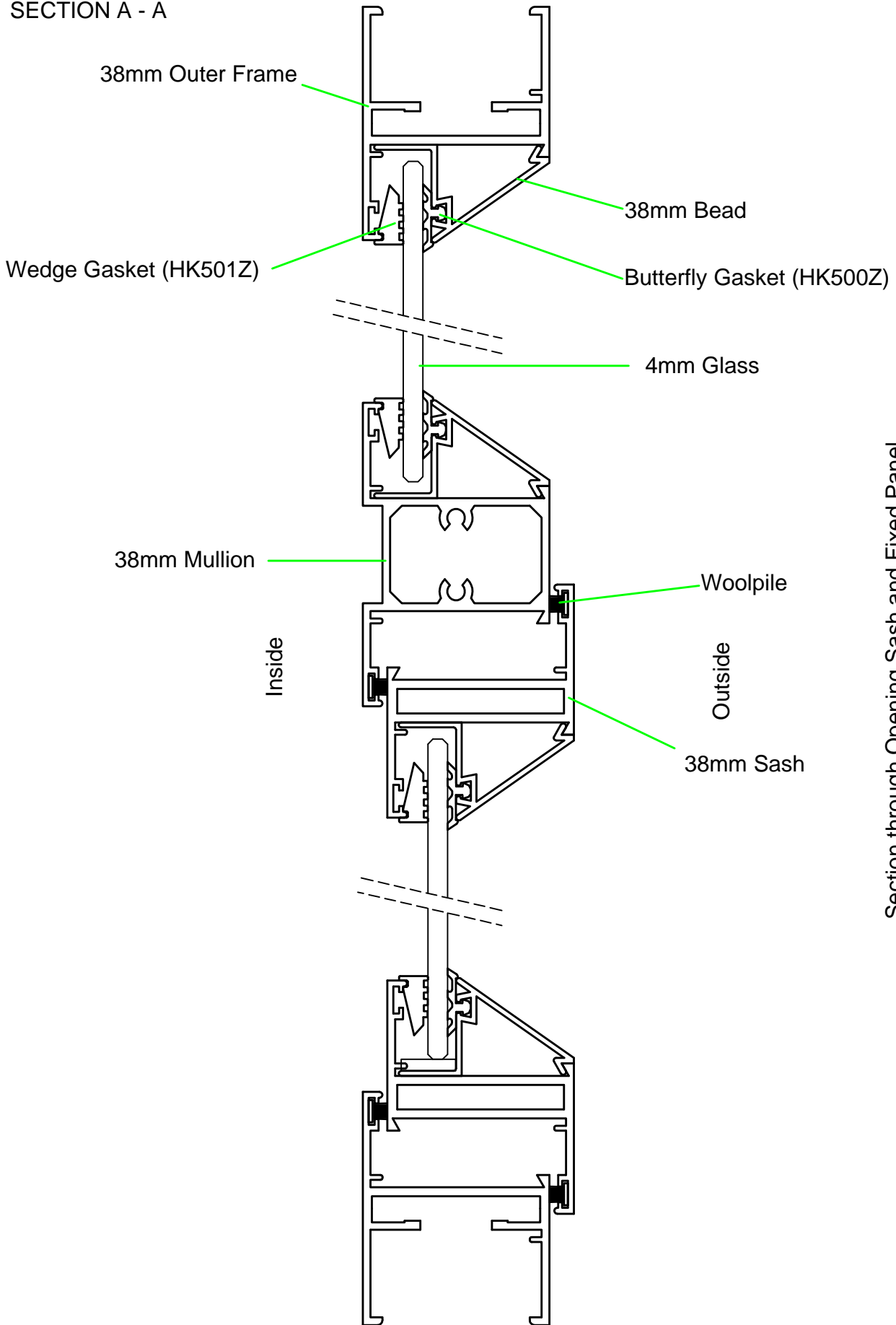

Section through Opening Sash and Fixed Panel

Overall Horizontal Cross Sections



SECTION B - B

Inside

Outside

Section through Outer Frame with Two Fixed Panels

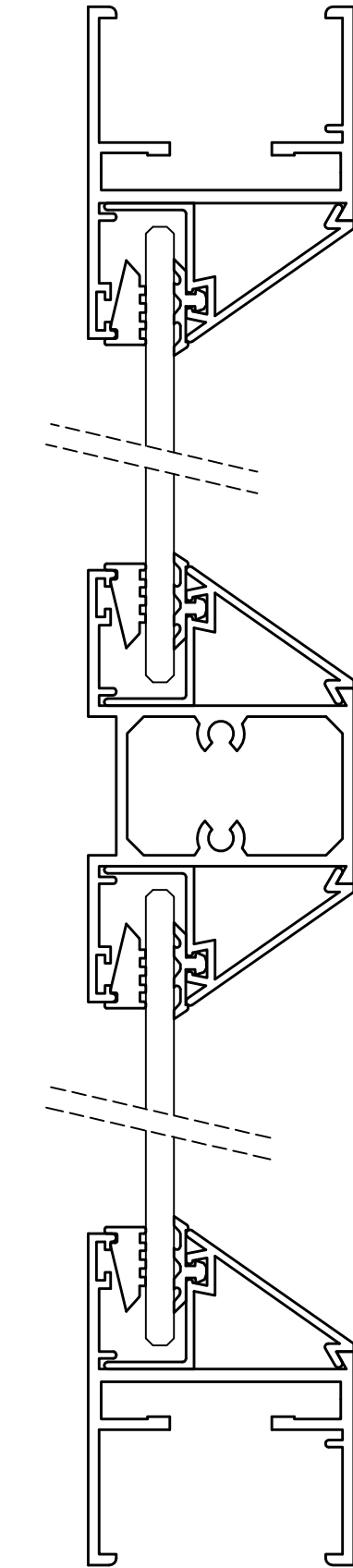

Overall Horizontal Cross Sections



SECTION C - C

Inside

Outside

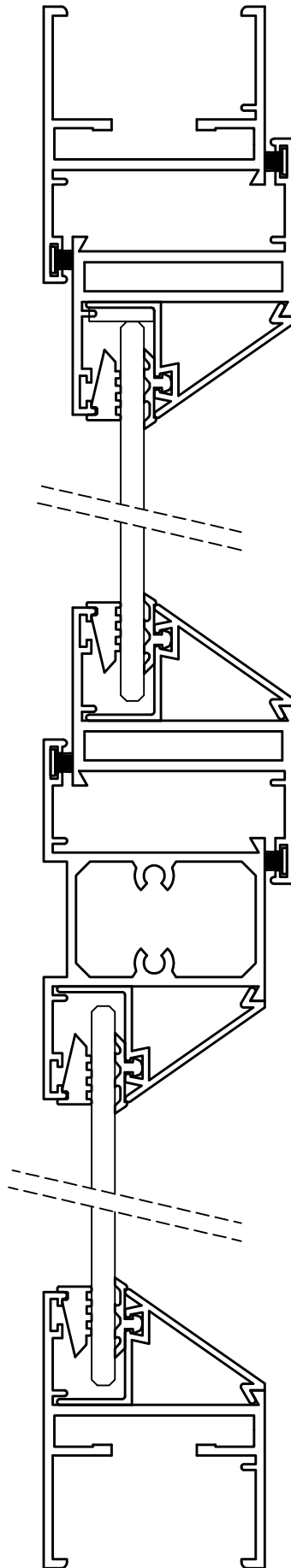

Section through Opening Sash and Fixed Panel
Overall Vertical Cross Sections

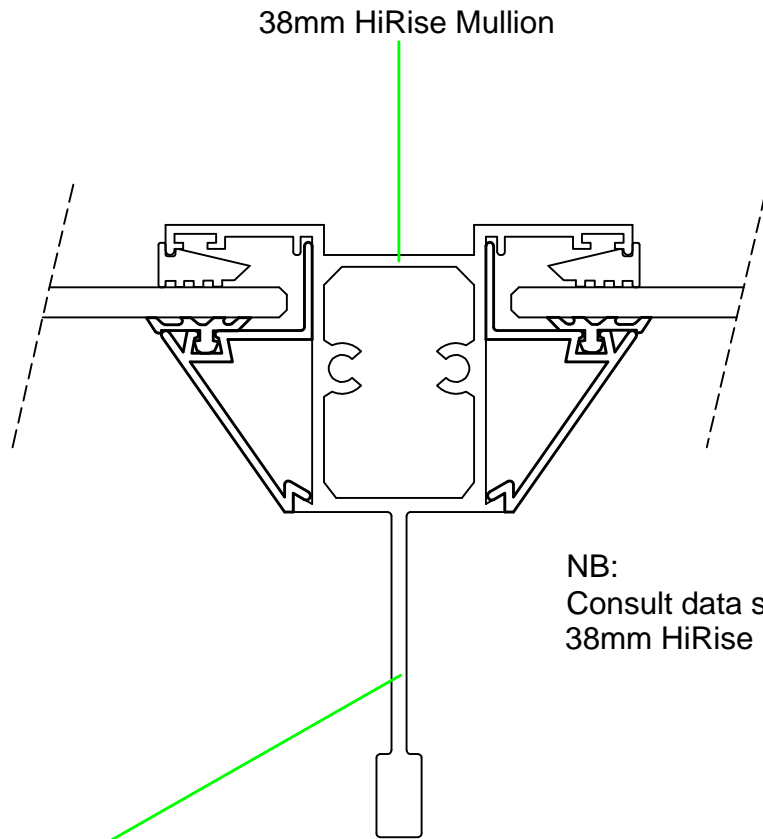
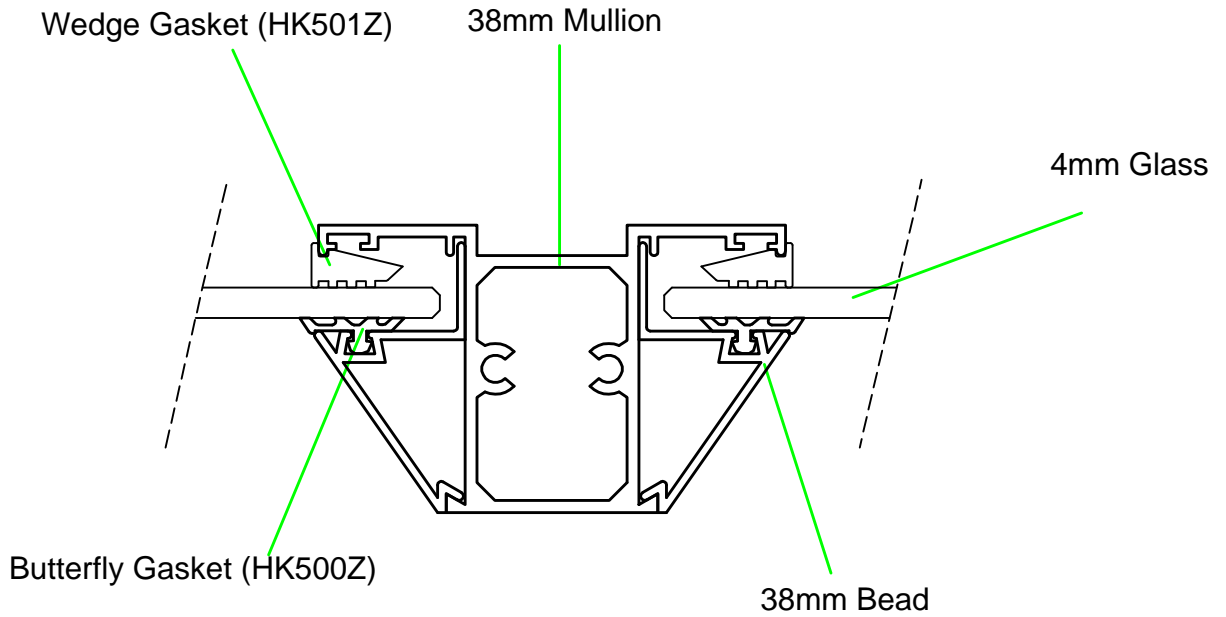

NB:
Consult data sheet for use of
38mm HiRise Mullion.

5 TIMES STRONGER THAN STANDARD 38mm MULLION
(STRUCTURAL PERFORMANCE AS NK26)

STANDARD & HI-RISE MULLION DETAILS

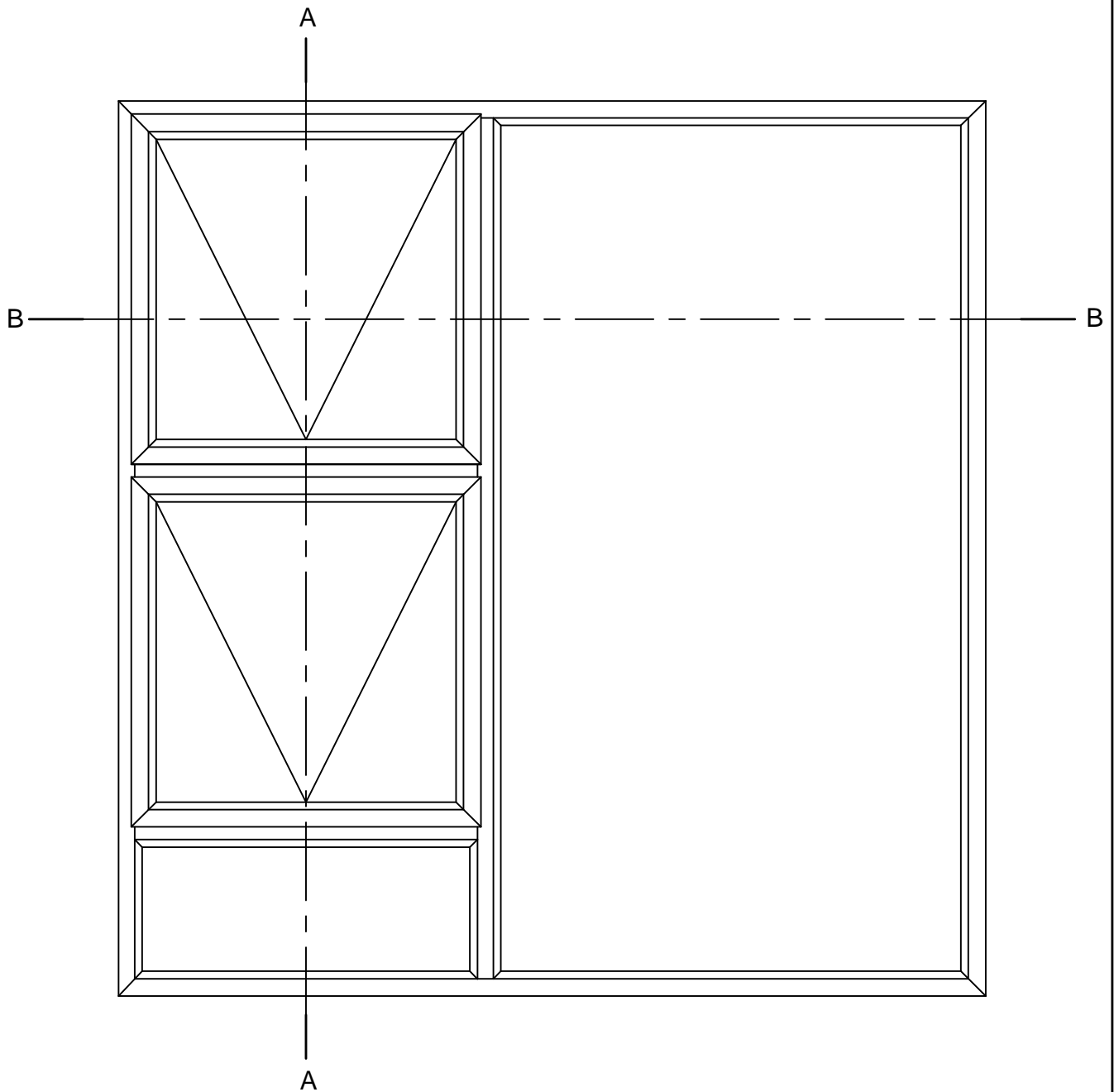

Typical Window Elevation with two Top Hung Sashes and two Fixed Panels
Detailed Elevations



SECTION A - A

Inside

Outside

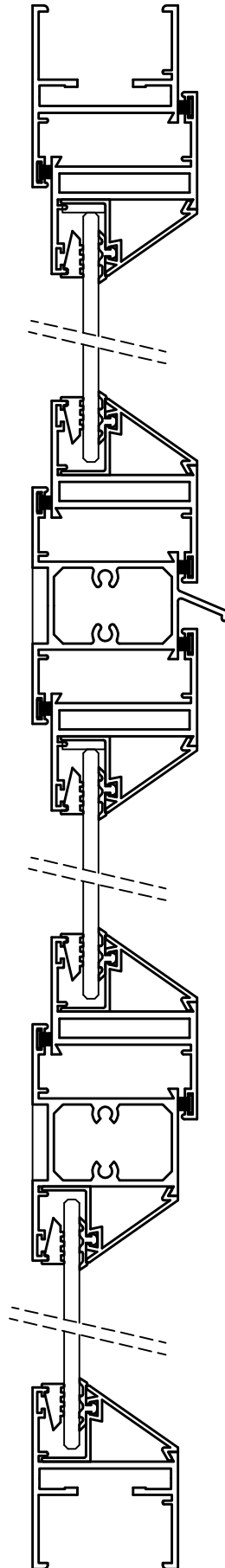

Section through two Opening Sashes and Fixed Panel
Overall Vertical Cross Sections

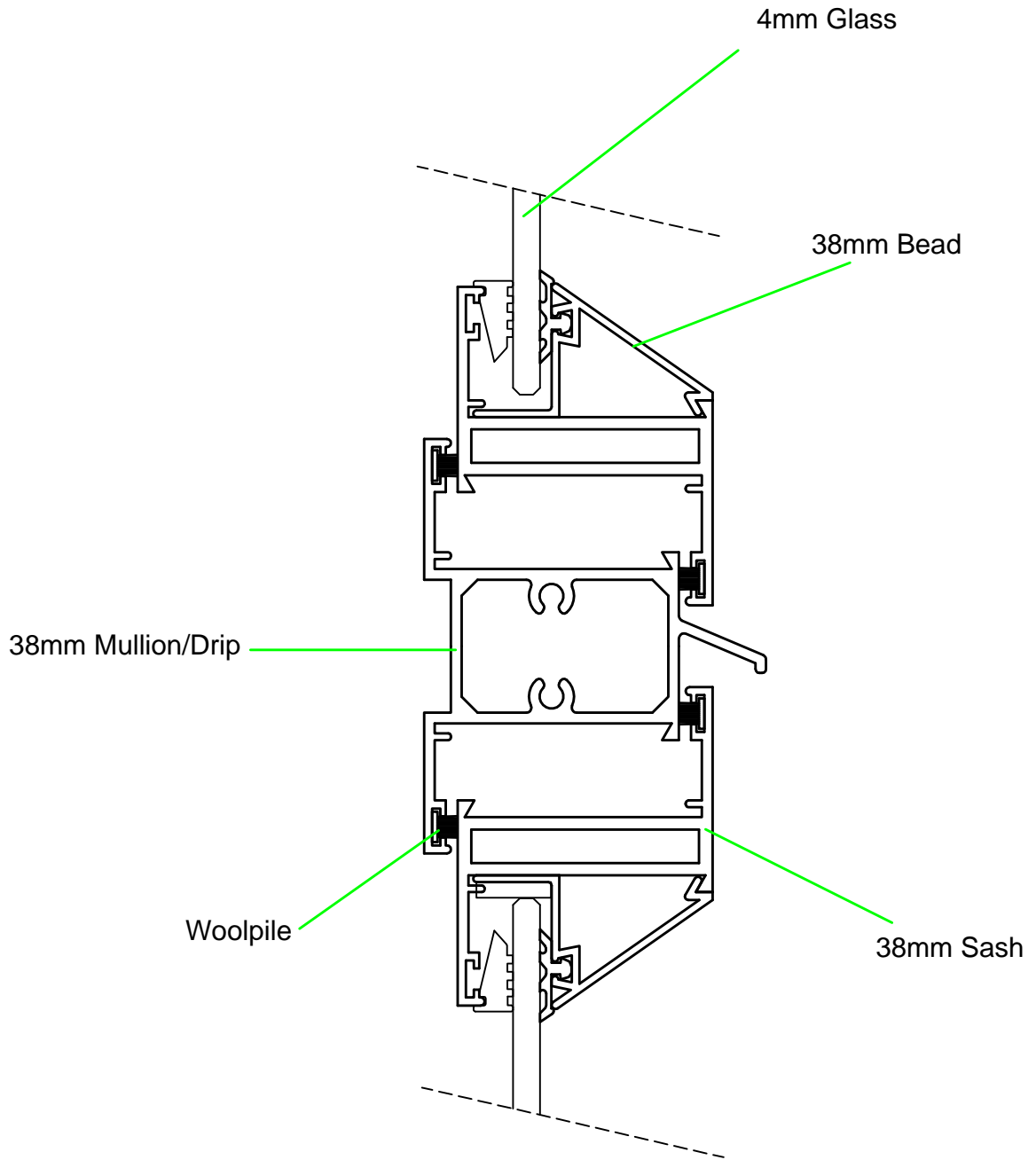

Section A - A Sash to Sash Transom details

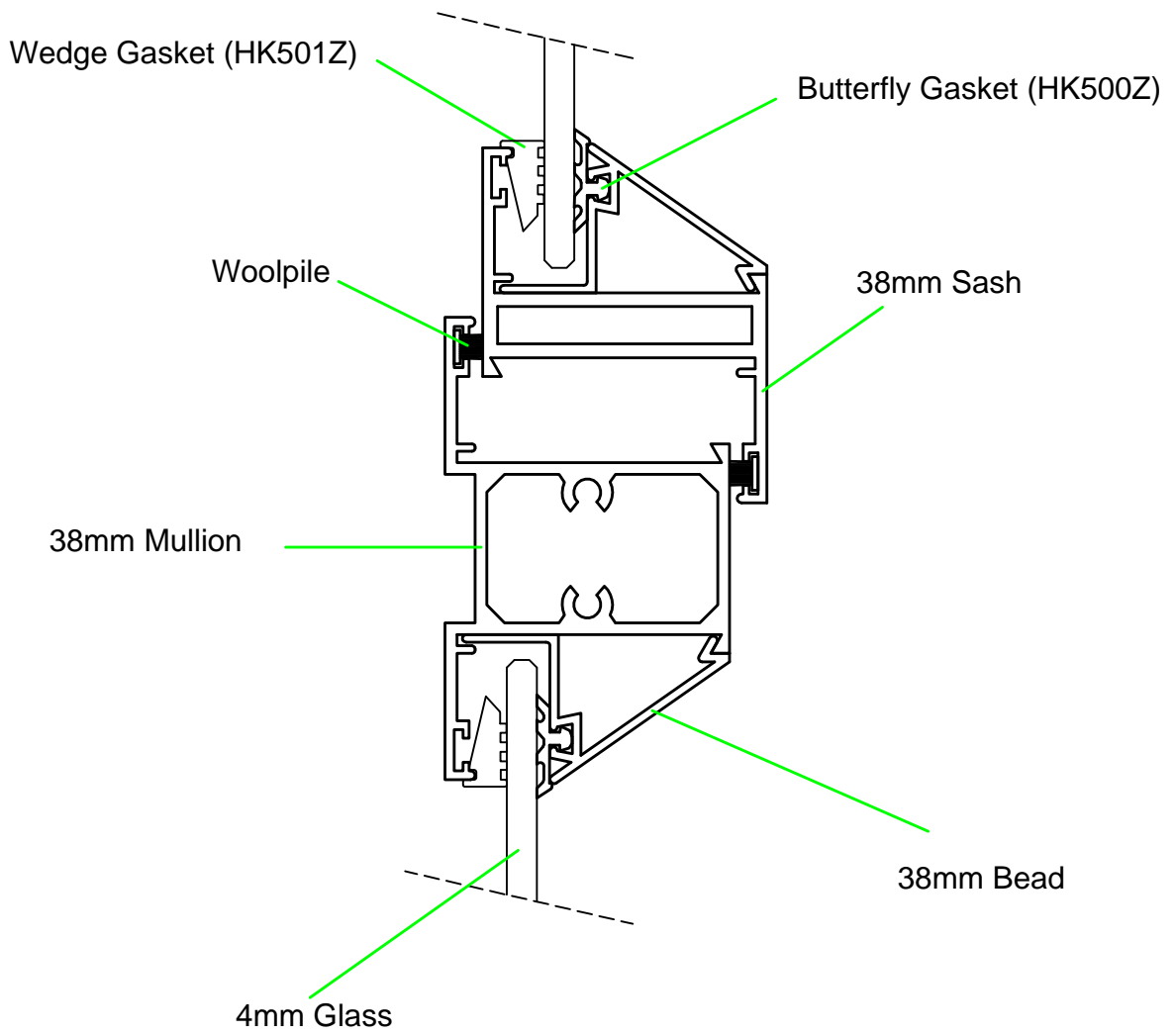

Section A - A Sash to Fixed light Transom details



SECTION B - B

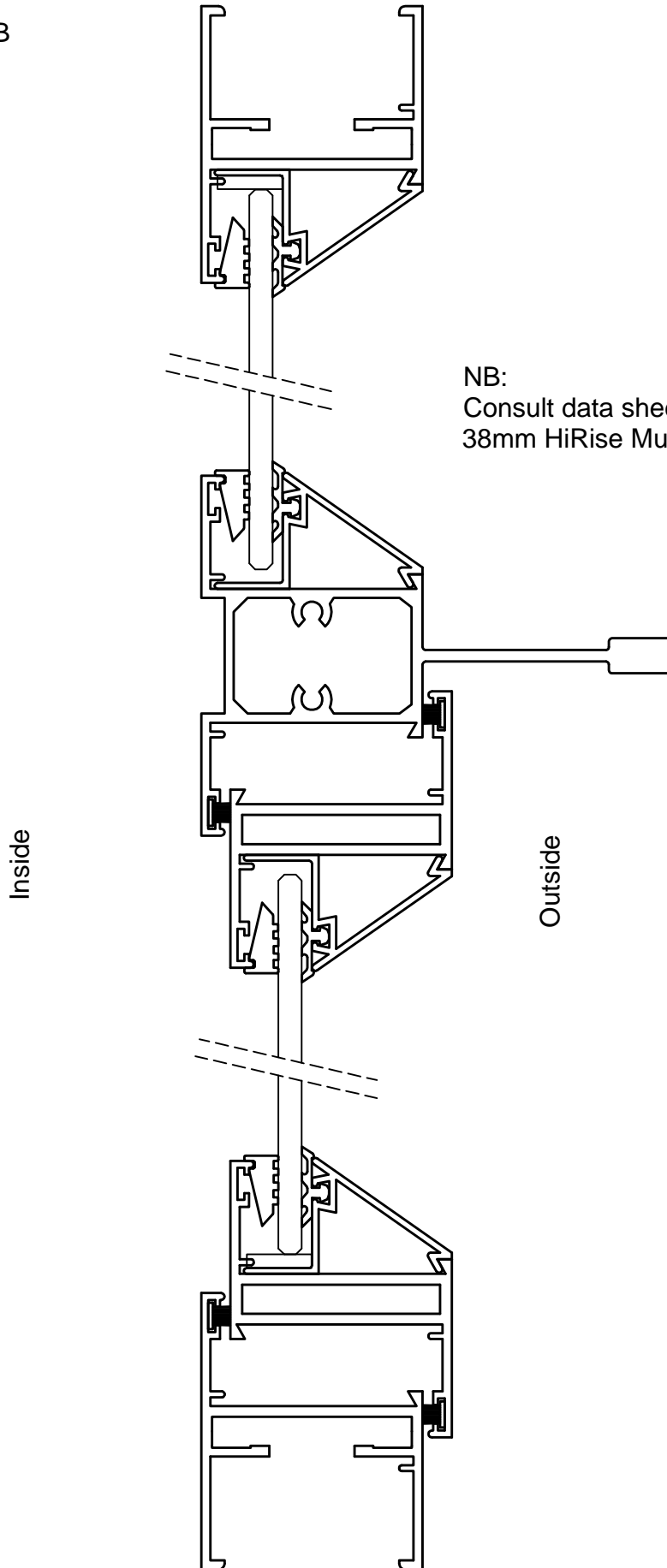

Alternative Cross Sections and Details

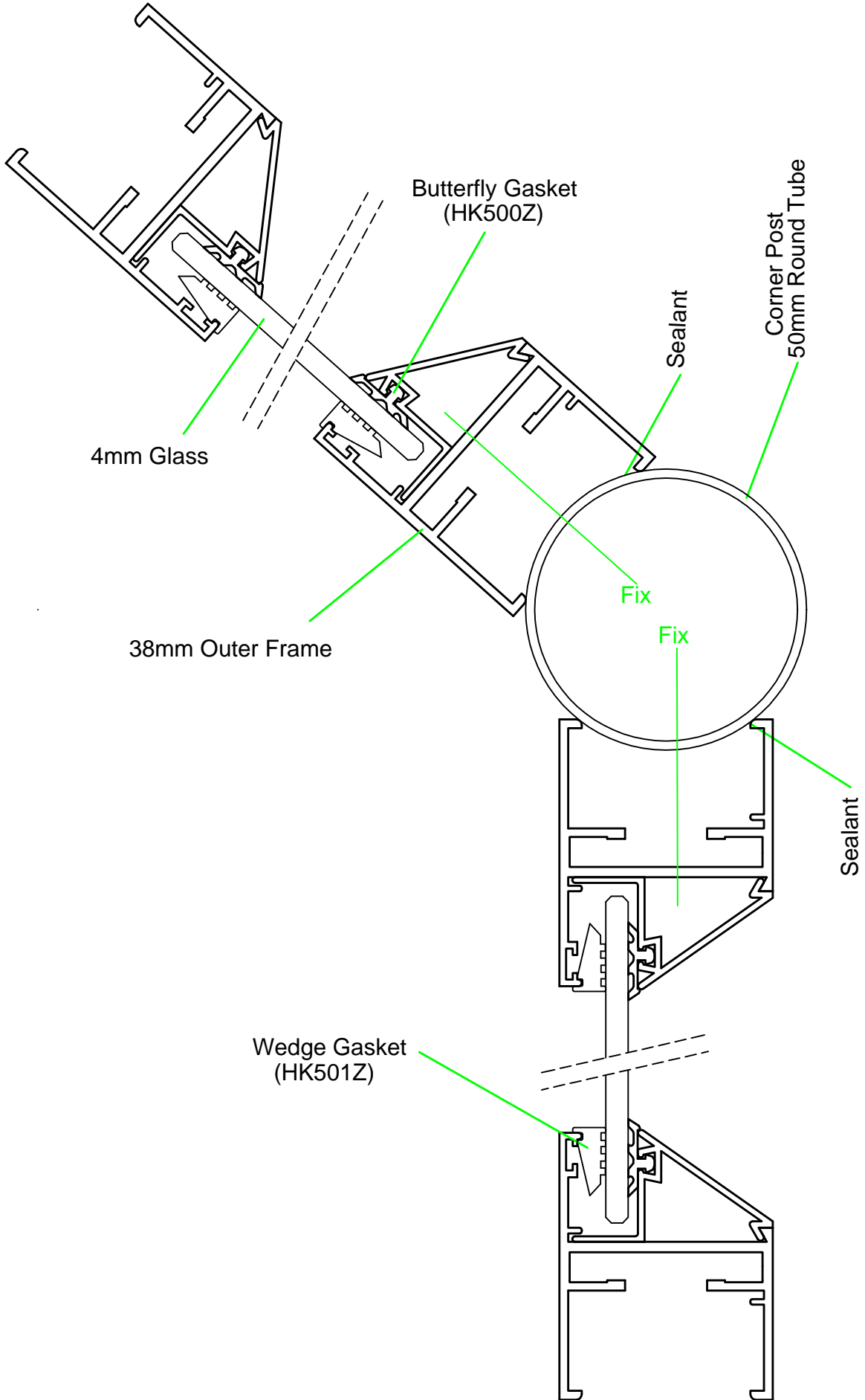

Possible Solution for Adjustable Corner
(e.g Bay Windows etc)

Adjustable corner layout for 38mm window

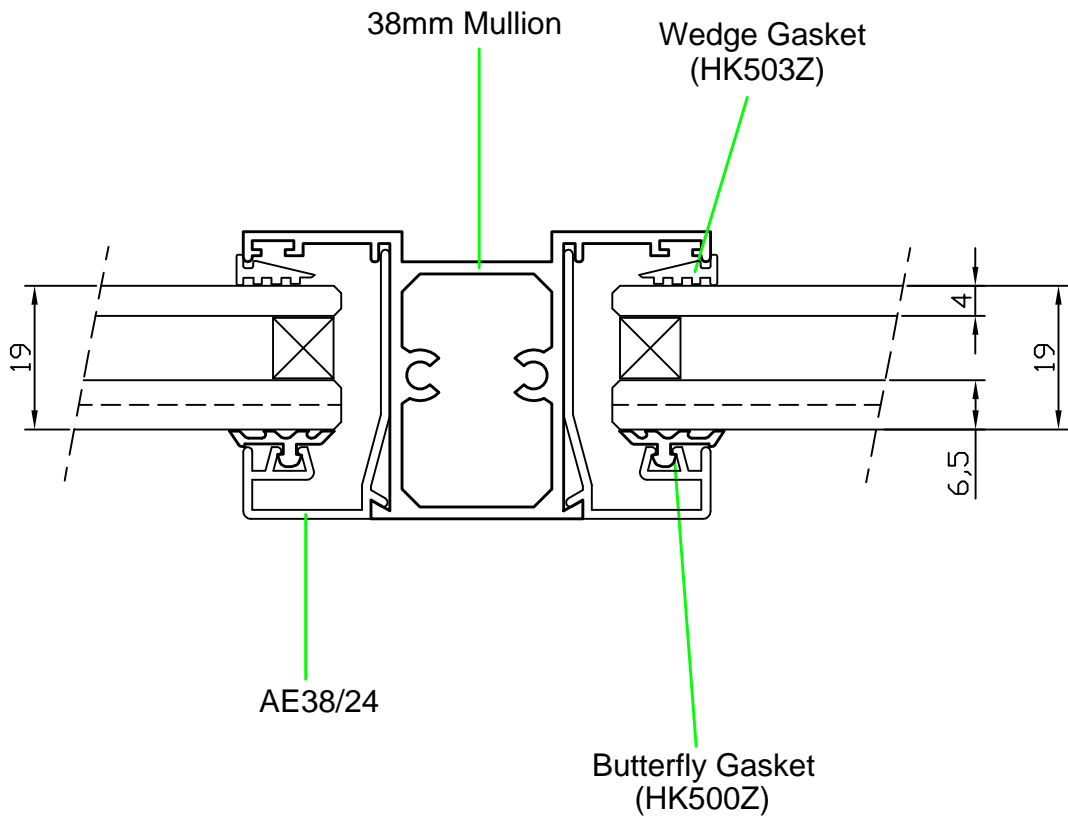
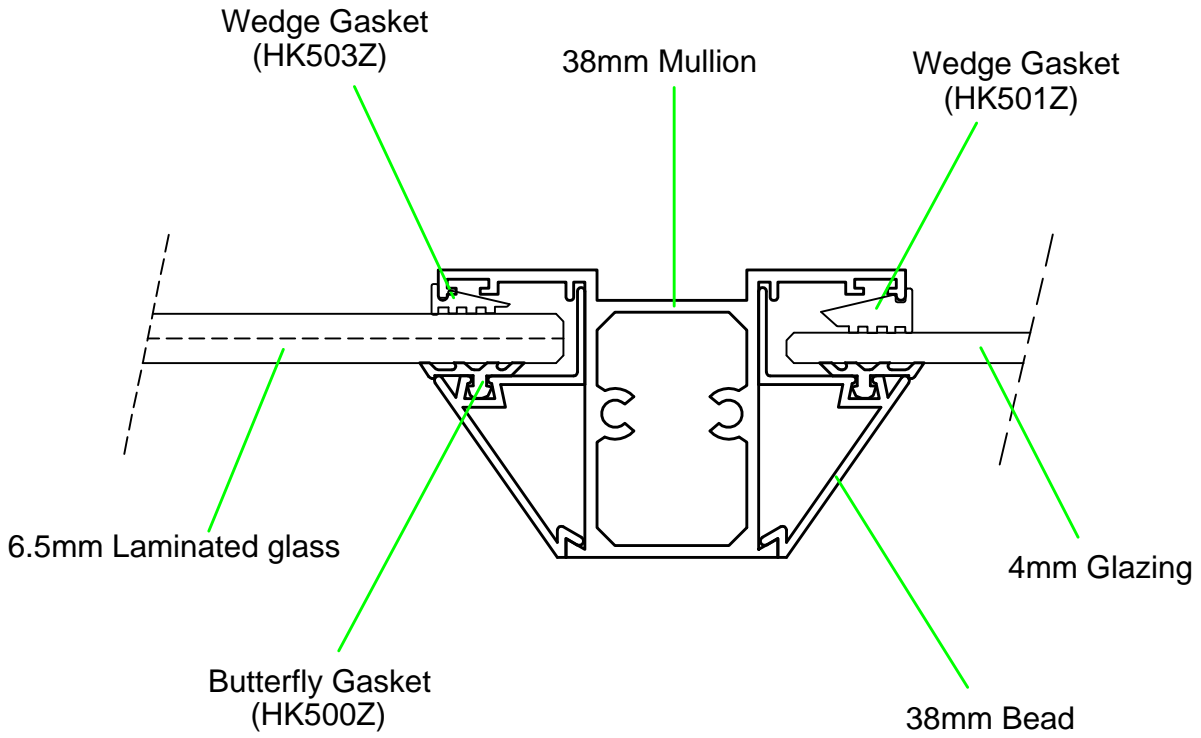

ALTERNATIVE GLAZING DETAILS